



Automatic Multi-Pallet Changer for 5th Axis and Standard VMCs



Midaco's Automatic Multi-Pallet Changer

Loads one pallet at a time and can change 19 pallets without an operator. Ideal for "Lights-Out" manufacturing. Retrofits to any **NEW** or **EXISTING** 5th Axis or Standard Vertical Machining Center.



Automatic Multi-Pallet Changer

- Includes 19 aluminum pallets:
10" (254mm) dia. and 1.25" (31.75mm) thick
Pallet weight capacity is 75 lbs (34.05 kg) ea.
- Hardened and ground locating pins assure +/- .0001" (.0025 mm) repeatability.
- Equipped with Mitsubishi controls, supported worldwide.
- Pallet Changer integrates with the machine by using M-functions.

Dual Air Blast

Cast iron receiver mounts directly to the machine table

(does not require pneumatics or hydraulics)

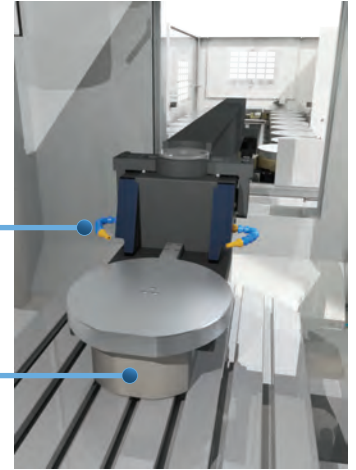

Full CE enclosure. Pallet change will not occur if doors are opened

Servo Driven



2 "Drop-Down Door" loading stations
(one on each side of machine)

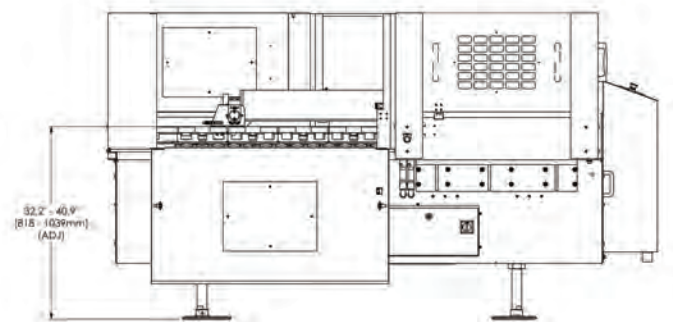
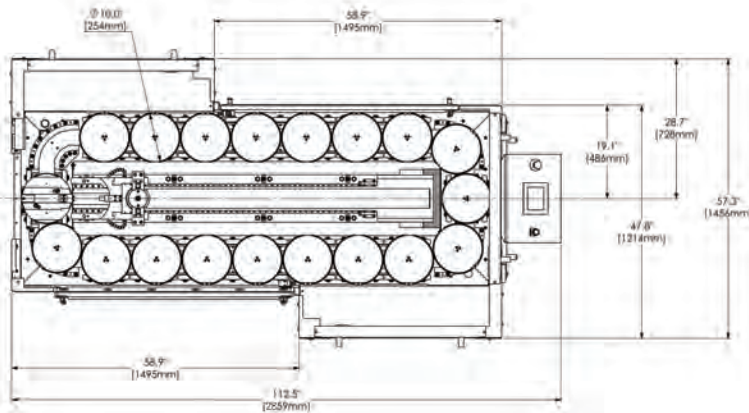
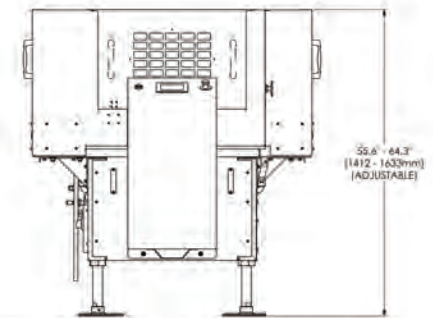

MIDACO pallet systems are designed for machines with stationary guarding. Some machines require options or customization. Patent pending. Contact your sales representative to confirm model and specifications for all applications. Machinery subject to modifications and amendments.



MIDACO CORPORATION
2000 E. Touhy Avenue
Elk Grove Village, IL 60007 USA
phone: (847) 593-8420
fax: (847) 593-8451
email: midaco@midaco-corp.com

KEEP THE SPINDLE RUNNING!

See how we fit your application
www.midaco-corp.com

